

# Tube-Line Bale Processor Boss I

Operator's Manual

2010

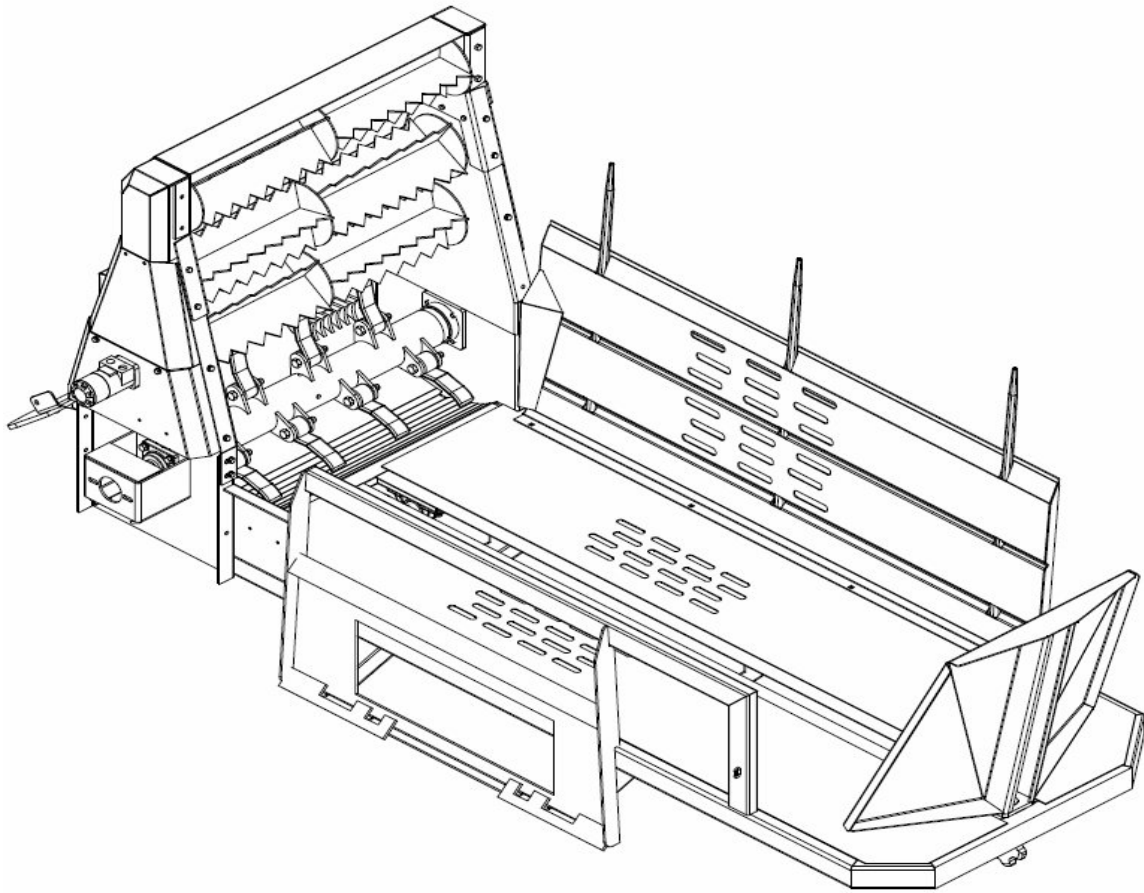

**TUBE•LINE**<sup>™</sup>  
MANUFACTURING LTD.



# TABLE OF CONTENTS

Owner and Operator and Safety Information .....	3-6
Definitions of Safety Terms and Symbols, Accident Prevention ...	3
Safety Instructions .....	4-5
Safety Signs .....	6
Power Unit Specifications .....	7
Installation Instructions .....	7
Hydraulic Instructions .....	7
Operation .....	8
Maintenance .....	9
Service .....	9
Grease Points .....	10
Deck Assembly .....	11
Top Beater Assembly .....	12
Bottom Beater Assembly.....	13
Ram Assembly .....	14
Hydraulic Schematic .....	15
Warranty Policy.....	16

## **TUBE•LINE Manufacturing**

3928 Steffler Road  
RR# 4  
Elmira, ON N3B 2Z3  
Canada  
1-888-856-6613  
Fax 519-664-0492  
[sales@tubeline.com](mailto:sales@tubeline.com)  
[www.tubeline.com](http://www.tubeline.com)

# INTRODUCTION

Thank you for purchasing your new **Boss I square bale processor**. Your Boss I was designed to load and shred all types of forage in large square bales up to 1500 pounds (680 kg). Maximum length of bales is 84" (213 cm) X 36" (91 cm) X 36" (91 cm)

The **Boss I square bale processor** has multiple uses:

Laying windrows in open fields.

Filling feed bunks – fence line, circular, etc.

Spreading forage for livestock bedding.

Spreading mulch over perennial plants such as strawberries and mushrooms.

The **Boss I** was carefully designed and manufactured to give you many years of dependable service. You or any other person, who will be assembling, operating, maintaining or working with this product, are required to read and completely understand the information and instructions contained in this manual. If anyone does not fully understand every part of this manual, please obtain further assistance by contacting the dealer from which this product was purchased or by contacting Tube-Line at the telephone number or address listed on the previous page of this manual. Keep this manual available for reference whenever this product is being handled or used. Provide this manual to any new owners and/or operators.

## GENERAL INFORMATION

The purpose of this manual is to assist you in safely assembling, mounting, operating and maintaining your Boss I. Read this manual carefully to obtain valuable information and instructions that will help you achieve safe and dependable service. The illustrations and data used in this manual were current at the time of printing, but due to possible engineering and/or production changes, this product may vary slightly in detail. Tube-Line reserves the right to redesign and/or change components as necessary without notification.

Throughout this manual, references may be made to:

Power Unit	The engine-driven machine to which this product must be attached.
Right, Left, Front, Rear	Directions which are determined in relation to the operator of the equipment when seated in the normal operating position.
<b>IMPORTANT</b>	Precautions that must be followed to prevent damage to equipment.
<b>NOTICE</b>	Precautions that must be followed to prevent substandard performance.

## SERIAL NUMBER LOCATION

Always refer to the model and serial number when ordering parts or requesting information from your dealer. The serial number plate is located on upper left front corner of the tub of your Boss I. Refer to diagram on page 6.

## DEFINITION OF SAFETY TERMS AND SYMBOLS

Throughout this manual, the terms **DANGER**, **WARNING** and **CAUTION** are used to indicate the degree of hazard to personnel if proper safety procedures are not followed. These words will be used in conjunction with the Safety Alert Symbol: a dark triangle containing a white exclamation mark.



The Safety Alert Symbol means:  
**- ATTENTION! - BECOME ALERT! - YOUR SAFETY IS INVOLVED!**

**DANGER** Indicates an imminently hazardous situation, which, if not avoided,  
**WILL result in death or serious injury.**

**WARNING** Indicates a potentially hazardous situation, which, if not avoided,  
**Could result in death or serious injury.**

**CAUTION** Indicates a potentially hazardous situation, which, if not avoided,  
**May result in minor or moderate injury;**

OR

May also be used to alert against unsafe practices, which **may result in damage to property.**

The safety information given in this manual does not replace any safety codes, insurance needs, federal, state and local laws.

**ACCIDENTS CAN BE PREVENTED WITH YOUR HELP!**

The best safety device is a careful operator. Tube-Line and your dealer ask that **YOU** be that careful, responsible equipment operator.

Pay attention to the job at hand. Do not let your mind lose concentration on what you are doing. No accident prevention program can be successful without the wholehearted cooperation of the person who is directly responsible for the operation of the equipment.

If accidents are to be prevented (*and accidents can be prevented*), that prevention will come from equipment operators who accept their complete responsibility and anticipate the results of their actions.

The designer, the manufacturer, and the safety engineer all help create a safe product, but their combined efforts can be wiped out with a single careless act by the operator of that product.

Do not attempt to operate this equipment under the influence of drugs or alcohol.

**YOU** ARE THE KEY TO SAFETY BECAUSE:

**YOU** are responsible for the SAFE operation and maintenance of **YOUR** Side Discharge Bucket.

**YOU** are responsible to familiarize yourself, and anyone else who will assemble, operate, maintain, or work around this product, with the safety information contained in this manual.

**YOU** are responsible to read ALL information contained in this manual to any operators or maintenance personnel who are not fully able to read the written English language. Whether **YOU** read the manual as written or translate it into another language, **YOU** must make certain that all operators and maintenance personnel have complete understanding of the full and exact contents of this manual.

**YOU** can reduce the risk of injury or death by following all safety precautions and by using good safety practices.

# Safety Instructions

WORK SAFELY – A CAREFUL OPERATOR IS THE BEST INSURANCE AGAINST ACCIDENTS!!



## SECTION 1 WARNING SECTION WARNING



Obey all safety instructions listed in this section and throughout this manual. Failure to obey instructions in this section could result in death or serious injury.

BEFORE ATTEMPTING ANY TYPE OF ASSEMBLY, OPERATION, MAINTENANCE OR OTHER WORK ON OR NEAR THIS PRODUCT:

READ AND COMPLETELY UNDERSTAND THIS MANUAL.

READ AND COMPLETELY UNDERSTAND THE MANUALS PROVIDED WITH YOUR POWER UNIT, LOADER AND QUICK-ATTACH. Read and understand all safety signs on this product and on your power unit, loader and quick-attach. Know all your controls and know how to quickly stop all power unit movements, the processor movement, and the engine in case of emergency. Know and obey all applicable government rules, O.S.H.A regulations, local laws and other professional guidelines for your operation. Make sure that anyone who will be assembling, mounting, maintaining, repairing, removing and/or storing this product: Has been instructed in the safe operation of this product and of the power unit and the quick-attach to which this product is attached. Is physically and mentally capable of the safe operation of this type of equipment. Is not under the influence of drugs or alcohol. Is carefully supervised from a safe distance, especially if such person is inexperienced.

Wears personal protective equipment (i.e. hardhat, safety glasses, work gloves, protective shoes, respirator, ear protection, etc.) Does not wear loose fitting clothes, loose or uncovered hair or any accessories (jewelry, necktie, scarf, wrist watch, etc.) that can catch and entangle on moving parts.

Has annually reviewed all safety instructions. Know and follow good work practices when assembling, mounting, maintaining, repairing, removing and storing this product: Work on a level surface in a well lit area. Keep the area clean and dry. Use properly grounded electrical outlets and tools. Use the right tool for the job at hand. Make sure that your tools are in good condition for performing the desired function. When using tools, wear the protective equipment specified by the tool manufacturer (i.e. hardhat, safety glasses, work gloves, protective shoes, etc.).

WHEN YOUR POWER UNIT IS USED DURING ANY TYPE OF ASSEMBLY, OPERATION, MAINTENANCE OR OTHER WORK ON OR NEAR THIS PRODUCT:

Before leaving the operator's station or before beginning any type of work on this product, lower this product to the ground, apply your power unit's parking brake, stop the engine, remove the starter key, wait for all moving parts to stop and then relieve all pressure in the hydraulic lines. *Refer to your power unit's operator's manual for instructions on how to relieve hydraulic pressure in lines.*

Know your loader's safe lifting and operating capacity and the weight of this product. See the specifications in this manual for the weight of this product and refer to your power unit's and loader's operator's manuals for safe operating limits. Lift capacity may be reduced if using a quick-attach.

Never allow anyone, except the operator, to be around the power unit or this product when either is in motion. Do not start up unless others are clear of the work area. Do not allow riders on this product or the power unit. Do not stand or climb on this product when raised. Do not place any part of your body under any part of this product unless this product is securely resting on adequate blocking or on the ground. Do not use blocking made of concrete blocks, logs, buckets, barrels or any other material that could suddenly collapse or shift positions. Do not use wood or steel blocking that shows any signs of material decay. Do not use wood blocking that is warped, twisted or tapered. Never operate controls from the ground. Operate the controls only from the operator's station. Never leave the equipment unattended with the engine running or with this product raised on the loader. Be aware of the added weight and width of this product. Reduce travel speeds accordingly, especially when traveling over rough ground. Keep this product close to the ground and under control when transporting. When transporting, be sure processor does not block view of vehicle lights or road.

## WARNING SECTION [Continued]

### **WARNING**

Obey all safety instructions listed in this section and throughout this manual. Failure to obey instructions in this section could result in death or serious injury.

#### **WHEN DEALING WITH HYDRAULICS DURING ANY TYPE OF ASSEMBLY, OPERATION, MAINTENANCE OR OTHER WORK ON OR NEAR THIS PRODUCT:**

Hydraulic fluid under pressure can penetrate the skin and cause serious injury or death. Hydraulic leaks under pressure may not be visible! If any fluid penetrates the skin, **GET IMMEDIATE MEDICAL ATTENTION!!** Wear safety glasses, protective clothing and use a sound piece of cardboard or wood when searching for hydraulic leaks. **DO NOT USE YOUR HANDS!**

Before connecting or disconnecting hydraulic hoses, read your tractor or power unit's operator's manual for detailed instructions on connecting and disconnecting hydraulic attachments. Make certain that all parts meet the specifications for this product when installing or replacing hydraulic hoses or fittings. After connecting hydraulic lines: Slowly and carefully raise the loader and cycle the rollback / dump cylinders to check hose clearances and to check for any interference. Operate the hydraulics on this product to check hose clearances and to check for any interference. Make certain that the hoses cannot interfere with or actuate the quick-attach mechanism. Make certain that hoses will not be pinched, or get tangled, in any equipment. Do not lock the auxiliary hydraulics of your power unit in the "ON" position.

Refer to your power unit's operator's manual and this manual for procedures and intervals, then inspect and maintain the entire hydraulic system to insure that the fluid remains clean, that all devices function properly and that there are no fluid leaks.

#### **WHEN MOUNTING THIS PRODUCT TO YOUR POWER UNIT:**

Refer to the operator's manuals of your power unit, your loader and your quick-attach for special or detailed mounting instructions. This product should fit onto the quick-attach or loader arms of your power unit the same as the original products that were designed by your loader / quick-attach manufacturer. If this product does not fit properly, contact Tube-Line before operating. Never place your finger into the mounting plate or 3-point hitch or loader holes. A slight movement of the power unit or this product could cause serious injury.

Make certain that all safety signs are in place and legible. Refer to the safety sign page in this manual for the placement of safety signs for this product. Inspect driveline shield for free rotation. Replace all damaged or excessively worn parts and hardware only with genuine Tube-Line parts or with properly rated fasteners, hydraulic hoses or fittings. Make certain that all locking pins, latches and connection devices are properly installed and secured. Make certain that all shields are in place and secure. Remove all foreign objects from processor.

Never use processor on a power unit that is not equipped with a cab or ROPS, and operator restraints (seat belts or equivalent devices).

Make sure bales are free from foreign objects.

Drive slowly through gates and doors.

Know your loader's safe operating weight limit and the weight of your loader attachment.

#### **WHEN ADJUSTING, SERVICING OR REPAIRING THIS PRODUCT:**

Make no modifications to your processor.

When making repairs, use only genuine Tube-Line parts or, for fasteners, hydraulic hoses or hydraulic fittings, use only properly rated parts.

Replacement parts, for parts with safety signs attached, must also have safety sign attached.

**Think SAFETY!  
Work SAFELY!**

## SAFETY SIGN LOCATIONS

### PLACEMENT OR REPLACEMENT OF SAFETY SIGNS

Clean the area of application with non-flammable solvent, then, wash the same area with soap and water. Allow the surface to fully dry. Remove the backing from the safety sign, exposing the adhesive surface. Apply the safety sign to the position shown in the diagram above and smooth out any bubbles.

### INSTRUCTIONS

Keep all safety signs clean and legible.

Replace all missing, illegible or damaged safety signs.

Replacement parts for parts with safety signs attached must also have safety signs attached.

Safety signs are available free of charge from your dealer or from Tube-Line.

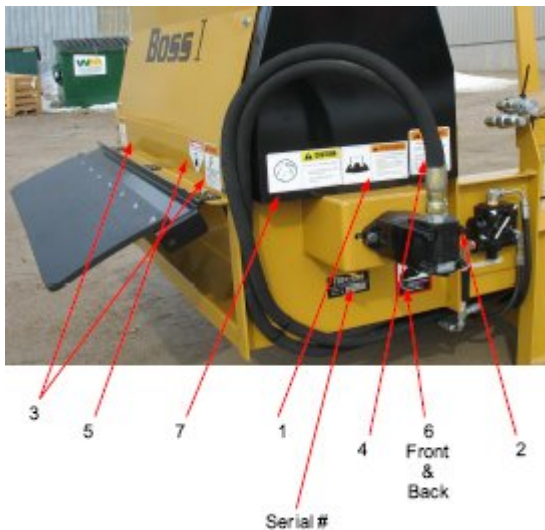





## POWER UNIT SPECIFICATIONS

**IMPORTANT** Exceeding any of the recommended power unit specifications **CAN** result in damage to your power unit and/or this product and **WILL** void all Tube-Line warranties.

Minimum	Maximum
20GPM at 2500PSI	40GPM at 3000PSI

## PROCESSOR INSTALLATION INSTRUCTIONS



**SAFETY FIRST!! READ AND UNDERSTAND THE SAFETY INSTRUCTIONS** (pages 3-6 of this manual) **BEFORE BEGINNING ANY PROCESSOR MOUNTING.**

Place this product on a firm, level surface that is large enough to safely accommodate this product, your power unit and all workers involved in the mounting process. Be sure all connection points are properly secured.

Refer to the operator's manual(s) for your power unit, loader and quick-attach and follow the mounting instructions contained therein.

Carefully raise the loader arms and cycle the tilt cylinders to check clearances and to verify that all mounting procedures have been successfully completed.

### Processor Hydraulic Connection



**SAFETY FIRST!! READ AND UNDERSTAND THE SAFETY INSTRUCTIONS** (pages 3-6 of this manual) **BEFORE BEGINNING ANY HYDRAULIC CONNECTION.**

Disconnect the hydraulic hose quick couplers from one another and attach the quick couplers to your power unit as per the instructions in your power unit's operator's manual.

Carefully raise the loader arm and cycle the tilt cylinders to check hose clearances and to check any interference.

### WARNING



Do not lock the auxiliary hydraulics of your tractor or power unit in the "ON" position. Failure to obey this warning could result in death or serious injury.

# PROCESSOR OPERATION



SAFETY FIRST!! READ AND UNDERSTAND THE SAFETY INSTRUCTIONS (*pages 3-6 of this manual*) BEFORE BEGINNING ANY PROCESSOR OPERATION.

## DANGER

Failure to obey the following procedure will result in death or serious injury. Avoid contacting overhead wires.

## WARNING

Failure to obey the following procedures could result in death or serious injury.

Never lift this product: above the operator's eye level OR to a height where visibility is obstructed, whichever is lower.

Use caution when raising loaded processor. Objects could fall from processor toward bystanders or operator. Remove all foreign objects from bales.

**NOTICE** Refer to your power unit's operator's manual for safe **operating limit** and use of **counterweights**.

To Load:

Load one bale at a time. If bales are frozen, put frozen side down to the table for better operation.

Center the bale on the forks before loading on to the table. Slide forks lightly on the ground when

loading bales. Store bales on level ground and on a clean surface free from rocks and other foreign objects.

– Adjust discharge deflector to spread forage at desired width.

– Operating power unit at maximum R.P.M. allows the processor to do a better job of chopping forage.

– Twine build - up should be kept to a minimum to reduce fire hazard and keep the machine in balance.

– Always lower the processor to the ground; set the parking brake; stop the engine; remove ignition key and wait for all moving parts to stop before leaving the operator's seat.

## PROCESSOR MAINTENANCE

Regular maintenance is the key to long equipment life and safe operation. It is very important that these maintenance functions be performed as described below.



**SAFETY FIRST!! READ AND UNDERSTAND THE SAFETY INSTRUCTIONS** (pages 3-6 of this manual)  
**BEFORE BEGINNING ANY PROCESSOR MAINTENANCE OPERATION**

### IMPORTANT

The flail tube on this machine is a fully balanced assembly. If for any reason the flails must be removed, **they must be returned** to the **same position** they were taken from. If this is not done a balance problem will result in causing machine vibration. Number flails and inserts and their positions before you do any work.

### BEFORE FIRST USE

Inspect the attachment for shipping damage. If damage does exist, do not operate until the damaged parts have been replaced or repaired.

### BEFORE EACH USE

Check for loose or badly worn parts.

Conveyor chain should be adjusted to allow chain slack 1" (2.54 cm) to 1½" (3.8 cm).

Make sure that all hydraulic fittings are tightened and that there are no leaks in any fittings or hoses.

Inspect rotor and all rotating parts for twine or wire build-up.

Check for cylinder wear and broken flails and flail bracket wear. Replace with new "Boss" flails to keep machine in balance.

Make sure that all safety signs are in place, are clean and are legible.

SEE THE SAFETY SIGN SECTION (page 6)

### AFTER EVERY 10 HOURS OF OPERATION

Grease all roller bearings. (refer to diagram on page 10)

Inspect and tighten Allen screws on bearing.

## PROCESSOR SERVICE



**SAFETY FIRST!! READ AND UNDERSTAND THE SAFETY INSTRUCTIONS** (pages 3-6 of this manual)  
**BEFORE BEGINNING ANY PROCESSOR SERVICE.**

### WARNING



Hydraulic fluid under pressure can penetrate skin, resulting in serious injury or death.  
Always relieve hydraulic pressure before disconnecting lines.

Shut off engine, set parking brake and relieve hydraulic pressure before connecting or disconnecting hydraulic lines. Refer to your power unit's manual for instruction on how to relieve hydraulic pressure in lines.

Before applying pressure to the system, be sure that all connections are tight and be sure there are no damaged hoses, lines or fittings.

Wear safety glasses and use metal or wood when searching for leaks. Do not use your hands.

### WARNING



Before servicing the loader, remove the attachment and make certain the lift arms are lowered to their lowest position or that the arms are supported by the mechanical lock up devices (if the machine is so equipped).

Steam-clean the power unit before any installation is made to the hydraulic system.  
Remove any attachment from the power unit and position on a level surface.

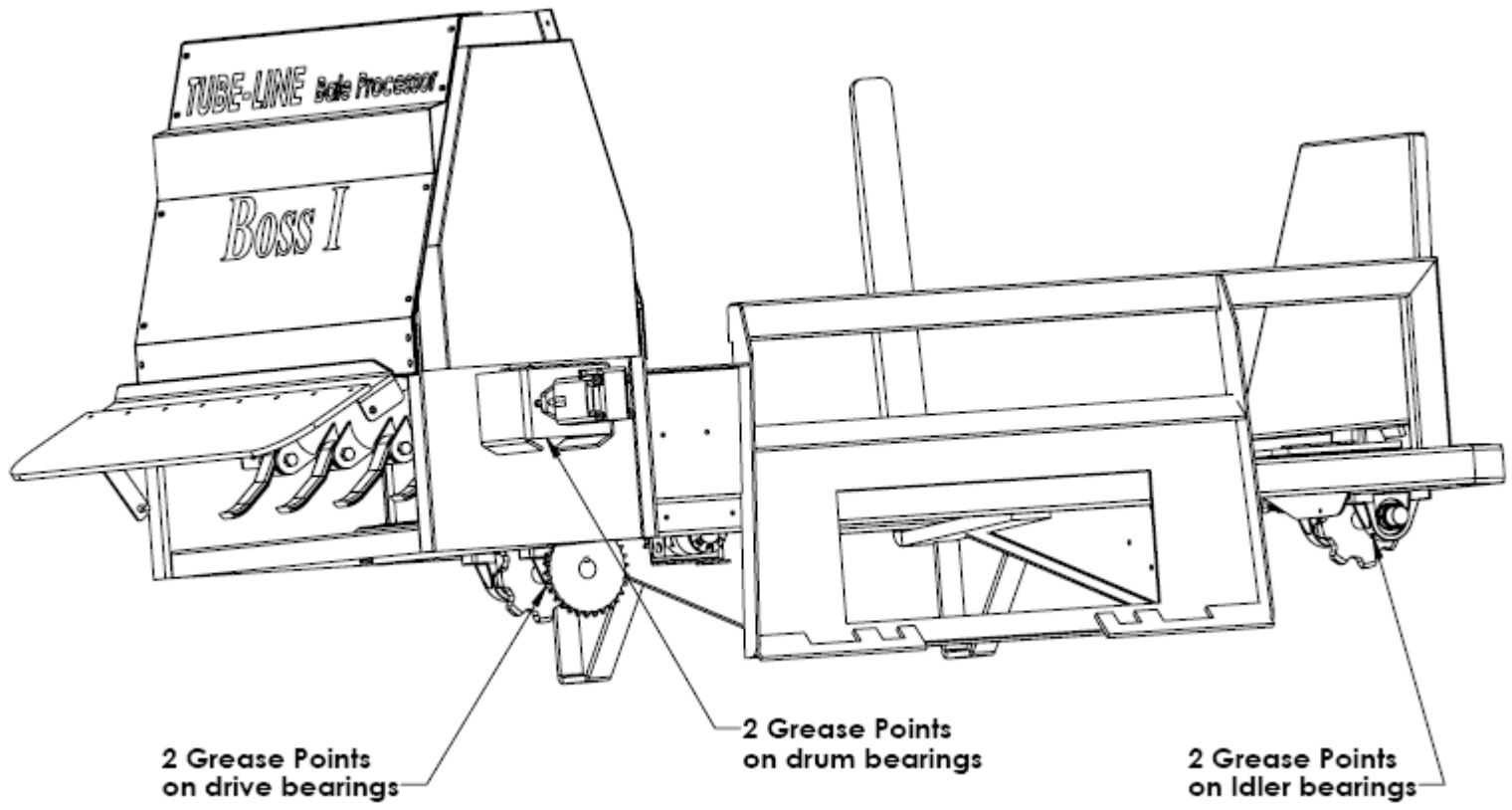





# Deck Assembly

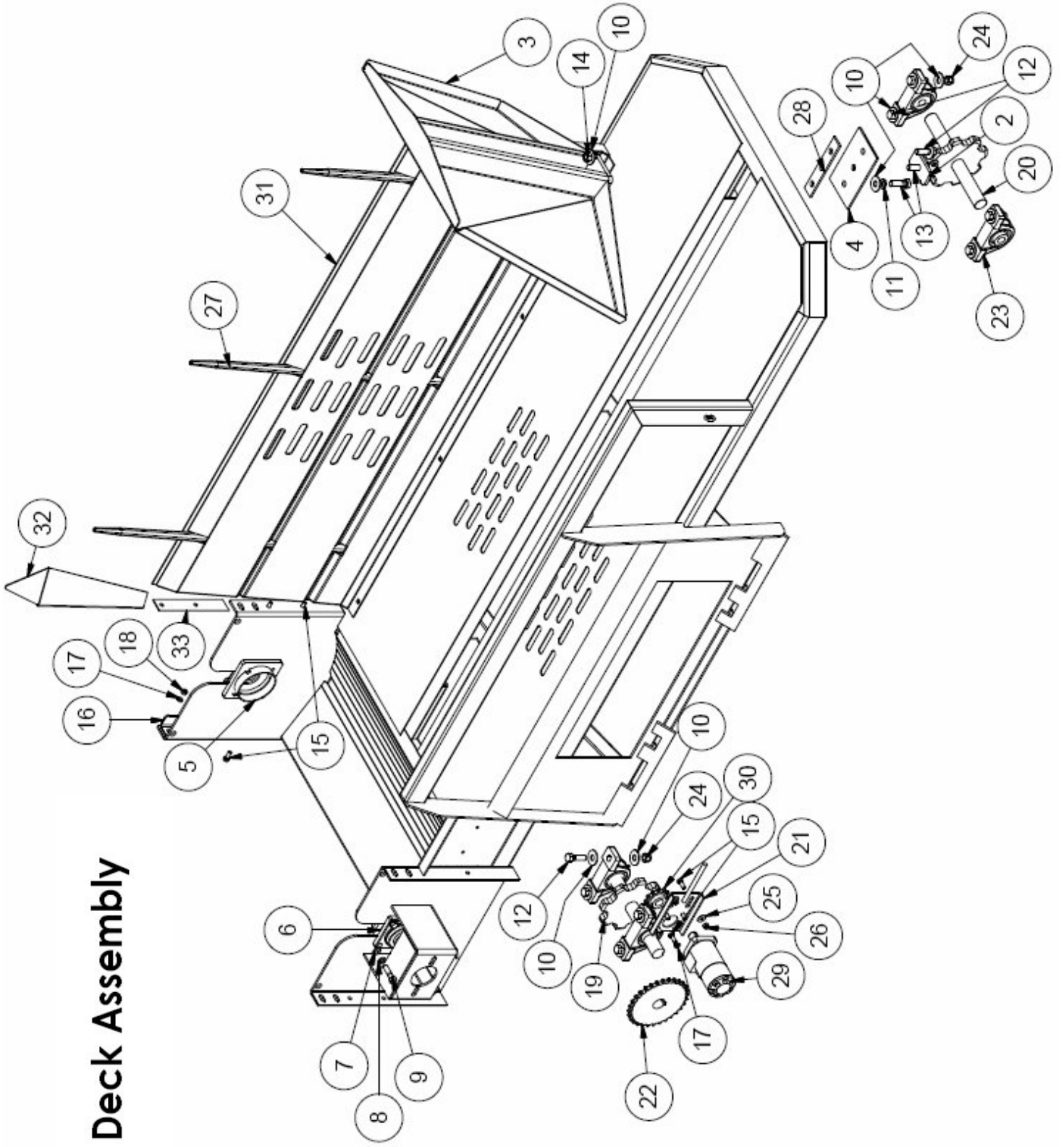



## Deck Assembly

<b>Item</b>	<b>Qty</b>	<b>Part #</b>	<b>Description</b>
1	1	B1 Deck 8	Deck Weldment
2	1	B1 089	Ram/Chain Attachment
3	1	B1 150	Ram
4	1	B1 123	Bottom Ram Slider Plate
5	2	B1 083	Bearing Guard
6	2	BEA UCF207-20	Bearing
7	8	FW 1/2	Flat Washer
8	8	LW 1/2	Lock Washer
9	8	HB 1/2 X 2	Hex Bolt
10	22	FW 5/8	Flat Washer
11	3	LW 5/8	Lock Washer
12	9	HB 5/8 X 2	Hex Bolt
13	2	HB 5/8 X 2.25	Hex Bolt
14	3	HN 5/8	Hex Nut
15	9	HB 3/8 X 1	Hex Bolt
16	1	B1 079	Adjuster Bracket
17	5	LW 3/8	Lock Washer
18	1	HN 3/8	Hex Nut
19	1	BS200141A	Sprocket Assembly
20	1	BS200138A	Chain Drive Sprocket
21	1	B1 082	Chain Tightener
22	1	SPR60B30F-IH	Sprocket
23	4	BS199398A	Drive Sprocket Bearing
24	8	LW 5/8	Lock Washer
25	2	FW 5/8	Flat Washer
26	2	LN 5/8	Lock Nut
27	3	LA-MFE43	Tine
28	1	B1 122	Ram Guide
29	1	VAL 1008	Motor
30	1	SPR60B11	Sprocket
31	1	25783	Loading Plate
32	1	26050	Bale Guide
33	1	26051	Bale Guide Spacer

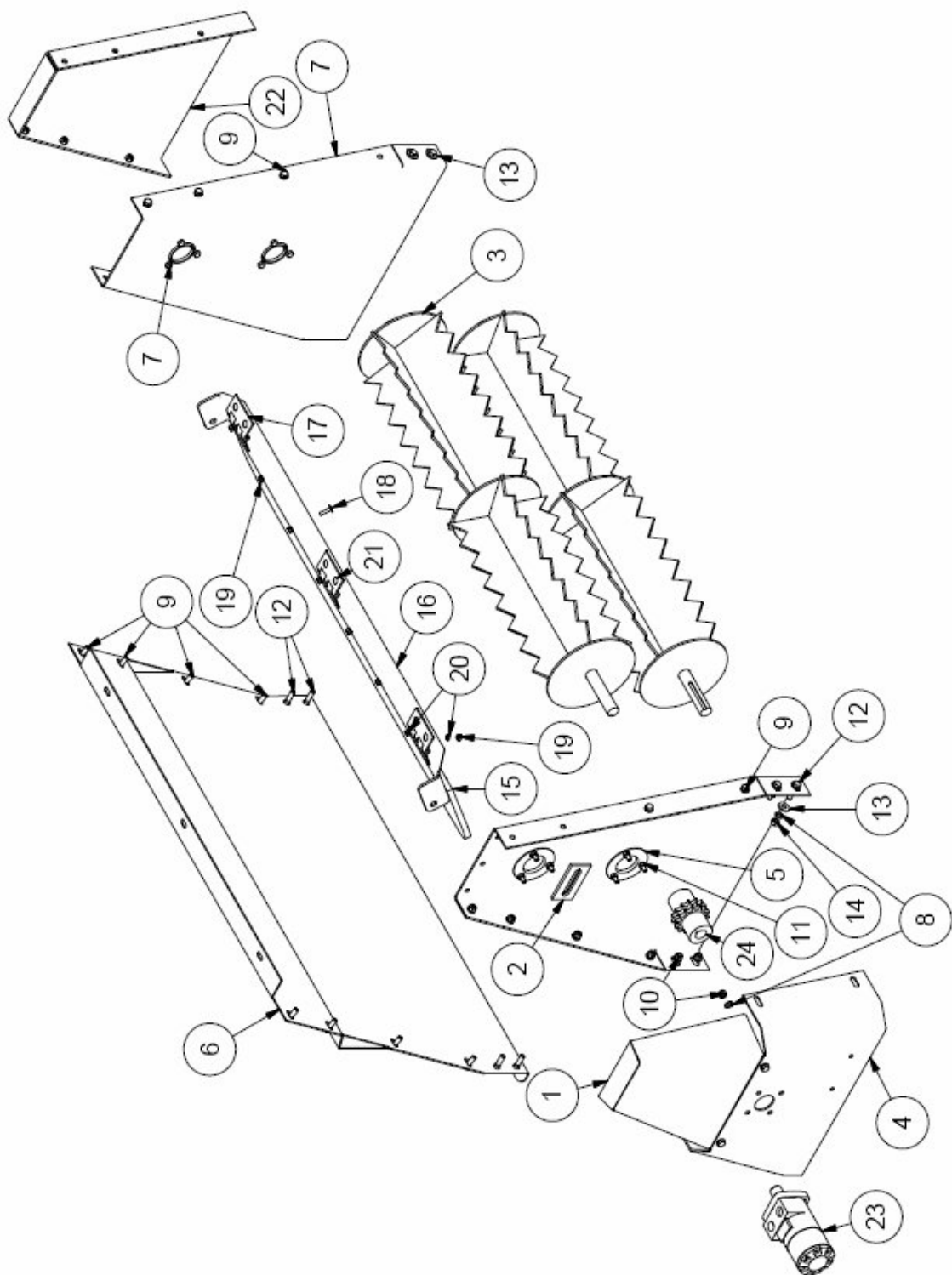

## Top Beater Assembly

<b>Item</b>	<b>Qty</b>	<b>Part #</b>	<b>Description</b>
1	1	25509	Top Beater Chain Shield
2	1	B1 080	Top Beater Side Plate
3	2	B1 084	Top Beater
4	1	B1 103	Top Beater Motor Mount
5	4	BEA PF205	Bearing
6	1	B1 081	Front Shield
7	1	B1 060	Top Beater Side Plate
8	38	LW 3/8	Lock Washer
9	15	HB 3/8 X 1	Hex Bolt
10	13	LN 3/8	Lock Nut
11	12	LN 5/16	Lock Nut
12	8	HB 3/8 X 1.5	Hex Bolt
13	6	FW 3/8	Flat Washer
14	4	HN 3/8	Hex Nut
15	1	B1 077	Rubber Deflector
16	1	B1 075	Rubber Deflector Mount
17	3	HIN 3.5 X 3.5	Hinge
18	8	CB 1/4 x 1	Round Head Bolt
19	14	HN 1/4	Hex Nut
20	14	LW 1/4	Lock Washer
21	6	CB 1/4 X .75	Round Head Bolt
22	1	25576	Top Beater Shield
23	1	VAL 1008	Motor
24	2	SPR5014F-1	14 Tooth Sprocket

★ 2 Square Keys are 1/4" x 2 1/2"

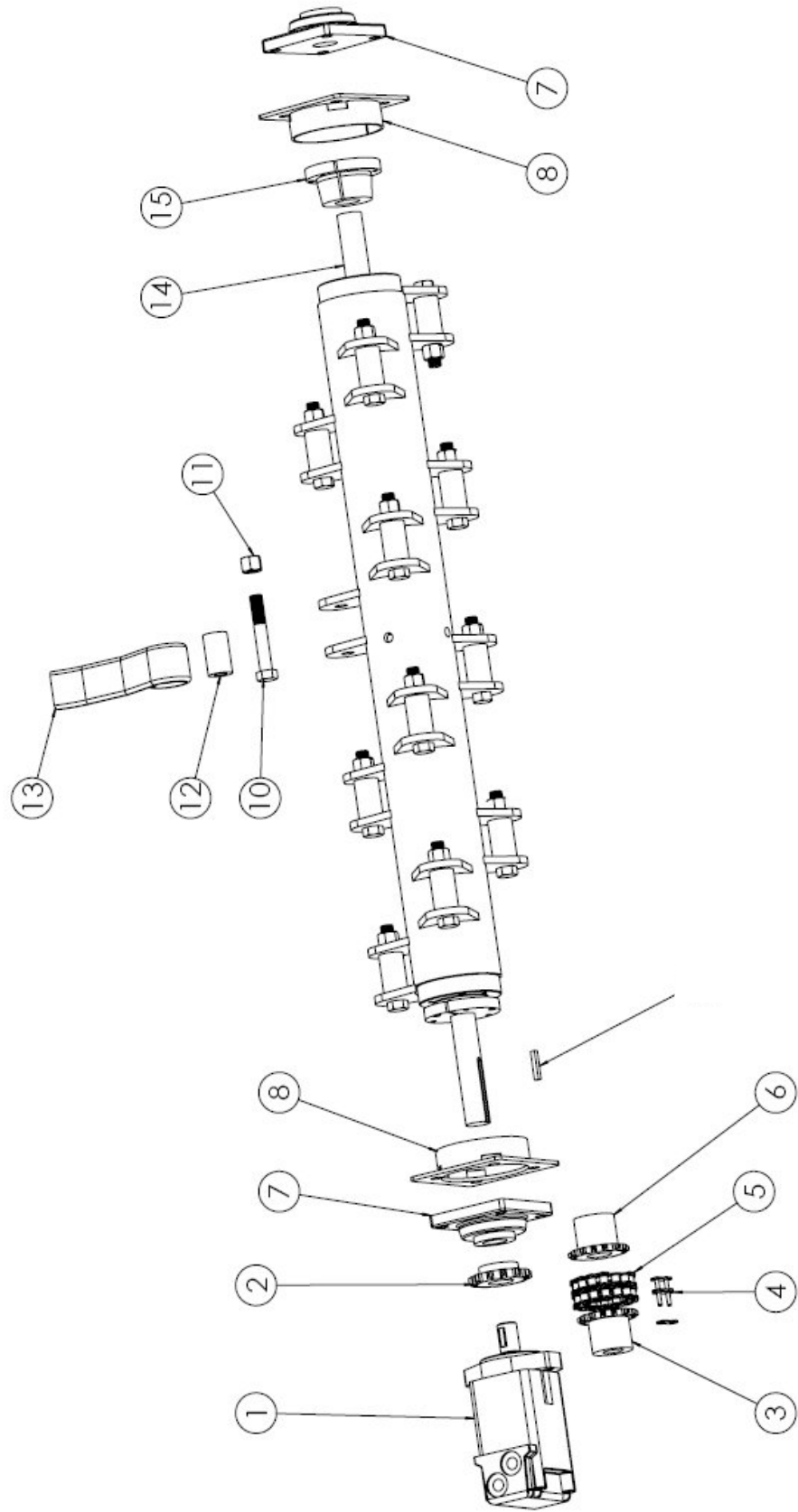

## Bottom Beater Assembly

Item	Qty	Part #	Description
1	1	25571	Flail Drum
2	1	BUSK 1/4TBW	SK Taper Lock Bushing 1 1/4" Bore
3	1	B1 032	1 1/4 Main Beater Shaft
4	1	B1 031	Flail Mount Lug
5	1	SAW200059	Flail Bushing
6	1	SAW200060	Flail
7	2	Obtain Locally	HN 5/8" Hex Nut
8	2	Obtain Locally	HB 5/8 x 4" Hex Bolt
			1/4" Square Key x 3"

# Hydraulic Schematic

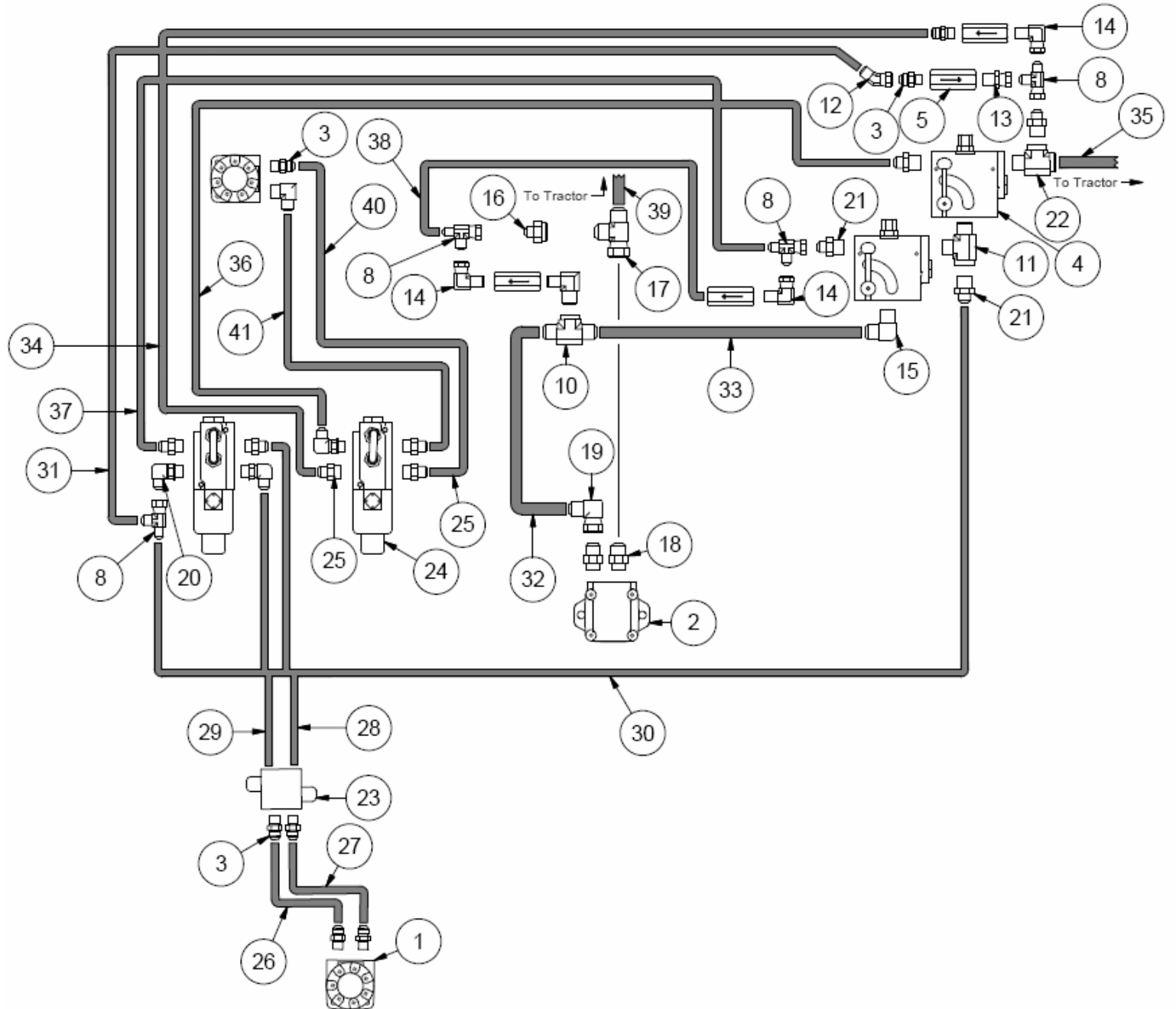

# Hydraulic Schematic

Item	Qty	Part #	Description
1	2	VAL 1008	Motor
2	1	VAL 1002	Motor
3	7	HF 2404-8-8	Hydraulic Fitting
4	2	VAL FCR51-34	Flow Control
5	4	VAL HYSITC4-07N	Check Valve
6	2	26030	Connector Tube
7	1	HF 2501-8-8	Hydraulic Fitting
8	4	HF 6602-8-8	Hydraulic Fitting
9	1	HF 5500-8-12	Hydraulic Fitting
10	1	HF 2602-12-12	Hydraulic Fitting
11	1	HF 5603-12-12	Hydraulic Fitting
12	1	HF 6502-8-8	Hydraulic Fitting
13	1	HF 6505-8-8	Hydraulic Fitting
14	3	HF 6501-8-8	Hydraulic Fitting
15	1	HF 2501-12-12	Hydraulic Fitting
16	1	HF 2406-12-8	Hydraulic Fitting
17	1	HF 6602-12-12	Hydraulic Fitting
18	2	HF 6400-12-10	Hydraulic Fitting
19	1	HF 6500-12-12	Hydraulic Fitting
20	3	HF 6801-8-10	Hydraulic Fitting
21	4	HF 2404-8-12	Hydraulic Fitting
22	1	HF 5602-12-12	Hydraulic Fitting
23	1	26215	Relief Valve
24	2	VAL DFE140	Diverter Valve
25	9	HF 6400-8-10	Hydraulic Fitting
26	1	26213	½ JIC X ½ JIC 90 (17")
27	1	26009	½ JIC X ½ JIC 90 (23")
29	1	26212	½ MP X ½ JIC 90 (23")
28	1	26211	½ MP X ½ JIC 90 (26")
30	1	26208	½ JIC X 2 (41")
31	1	26214	½ JIC X ½ JIC 90 (33")
32	1	26202	¾ SHORT JIC 90 X 2 (4.5")
33	1	26204	¾ JIC X 2 (10")
34	1	26209	½ JIC X ½ JIC 90 (22")
35	1	26205	¾ MP X 2 (76")
36	1	26218	½ JIC X ½ JIC 90 (18")
37	1	26210	½ JIC X ½ JIC 90 (25")
38	1	26207	½ JIC X ½ MP (7.5")
39	1	26206	¾ JIC X ¾ MP (108")
40	1	23307	½ JIC X ½ JIC 90 (26")
41	1	26219	½ JIC X 2 (22")

# Optional 3<sup>rd</sup> Beater Kit

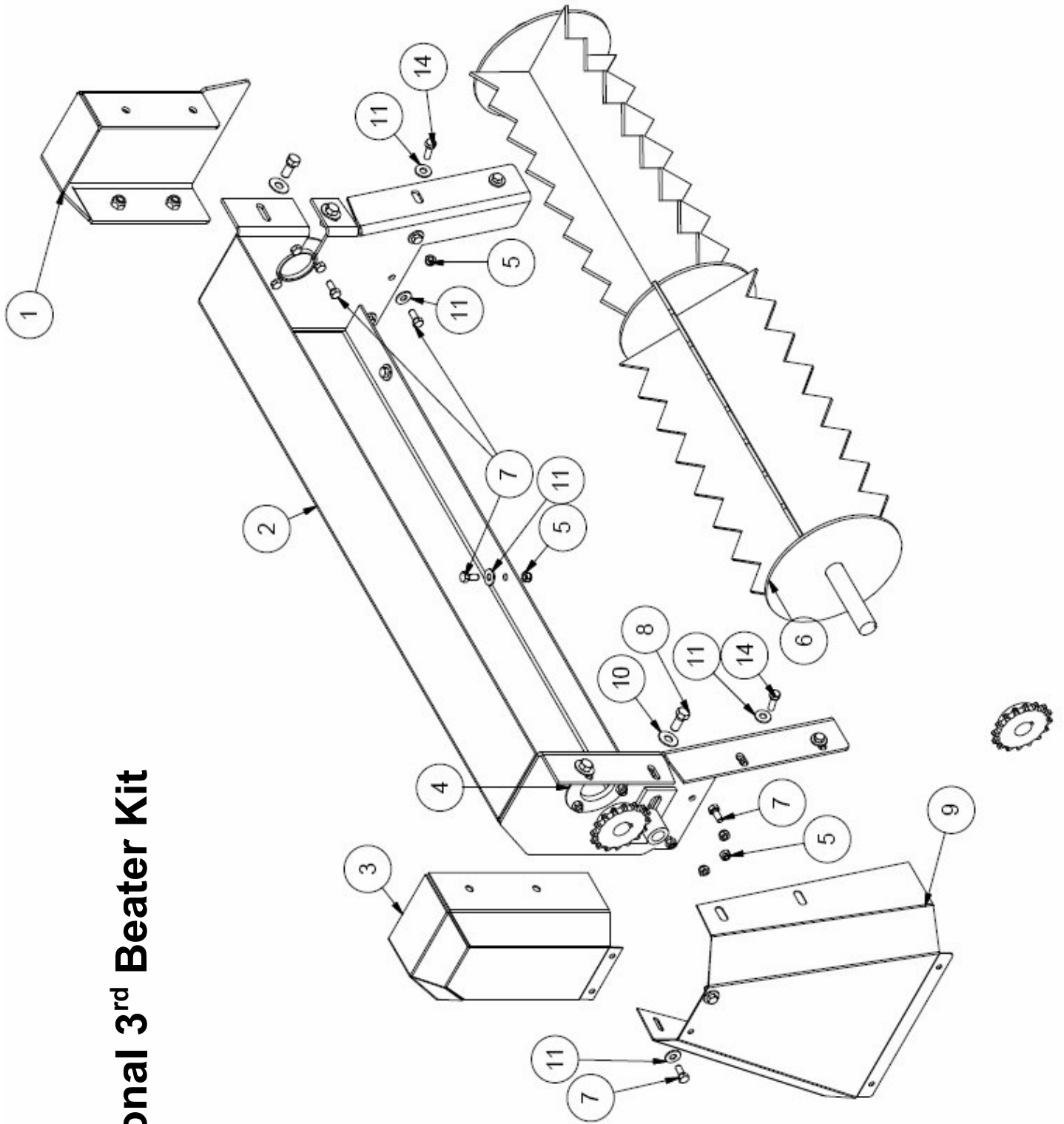



## Optional 3<sup>rd</sup> Beater Kit

<b>Item</b>	<b>Qty</b>	<b>Part #</b>	<b>Description</b>
1	1	26002	Front Shield
2	1	26000	3 <sup>rd</sup> Beater Main Guard
3	1	26001	3 <sup>rd</sup> Beater Chain Guard
4	2	BEA PF205	3 Hole Flange
5	17	Obtain Locally	LN 5/16 Lock Nut
6	1	B1 084	Top Beater
7	17	Obtain Locally	HB 5/16 x .75 Hex Bolt
8	6	Obtain Locally	HB 7/16 x 1 Hex Bolt
9	4	Obtain Locally	HB 5/16 x 1 Hex Bolt
10	4	Obtain Locally	LN 3/8 Lock Nut
11	1	25786	Middle Guard
12	6	Obtain Locally	FW 7/16 Flat Washer
13	7	Obtain Locally	FW 3/8 Flat Washer
14	8	Obtain Locally	FW 5/16 Flat Washer
15	2	Obtain Locally	LN 7/16 Lock Nut

Please read and understand this manual and the machine before operation.

### ***Warranty and Limitation Of Liability***

All Equipment is sold subject to mutual agreement that it is warranted by the company to be free from defects of material and workmanship. But the company shall not be liable for special, indirect or consequential, damages of any kind under this contract or otherwise. The company's liability shall be limited exclusively to replacing or repairing without charge, at its factory or elsewhere, at its discretion. Any material, or workmanship defects which become apparent within one year from the date on which the equipment was purchased, and the company shall have no liability for damages of any kind. The buyer by the acceptance of the equipment will assume all liability for any damages, which may result from the use or misuse by his employees or others.

Warranty coverage is null and void unless Warranty Registration form has been completely filled in and is on file at Tube-Line Manufacturing Inc.



**TUBE•LINE™**  
**MANUFACTURING LTD.**